

Annex D to the Level 2 – Level 3 Agreement is replaced by the following:

BANCODE **ESPAÑA**
Eurosistema

INFORMATION TECHNOLOGY COMMITTEE

ESCB-PKI SERVICES



OIDS: 0.4.0.127.0.10.1.2.3.0

**CERTIFICATE POLICIES FOR THE NON-ESCB/NON-SSM USERS'
CERTIFICATES**

VERSION 1.4

26 August 2019

Table of Contents

1	<i>Introduction</i>	9
1.1	Overview	9
1.2	Document Name and Identification	11
1.3	ESCB-PKI Participants	12
1.3.1	The Policy Approval Authority.....	12
1.3.2	Certification Authority	12
1.3.3	Registration Authorities	12
1.3.4	Validation Authority	12
1.3.5	Key Archive	12
1.3.6	Users	12
1.4	Certificate Usage	13
1.4.1	Appropriate certificate use	13
1.4.2	Certificate Usage Constraints and Restrictions	13
1.5	Policy Approval	13
1.6	Definitions and Acronyms	13
1.6.1	Definitions	13
1.6.2	Acronyms.....	14
2	<i>Publication and Repository Responsibilities</i>	15
2.1	Repositories	15
2.2	Publication of Certification Data, CPS and CP	15
2.3	Publication Timescale or Frequency	16
2.4	Repository Access Controls	16
3	<i>Identification and Authentication (I&A)</i>	17
3.1	Naming	17
3.1.1	Types of names	17
3.1.2	The need for names to be meaningful	17
3.1.3	Rules for interpreting various name formats	17
3.1.4	Uniqueness of names	17
3.1.5	Name dispute resolution procedures	17
3.1.6	Recognition, authentication, and the role of trademarks	17
3.2	Initial Identity Validation	17
3.2.1	Means of proof of possession of the private key	17
3.2.2	Identity authentication for an entity	18
3.2.3	Identity authentication for an individual	18
3.2.4	Non-verified applicant information.....	19
3.2.5	Validation of authority	19
3.2.6	Criteria for operating with external CAs.....	19
3.3	Identification and Authentication for Re-key Requests	19

3.3.1	Identification and authentication requirements for routine re-key	19
3.3.2	Identification and authentication requirements for re-key after certificate revocation	19
4	<i>Certificate Life-Cycle Operational Requirements</i>	20
4.1	Certificate Application	20
4.1.1	Who can submit a certificate application?	20
4.1.2	Enrolment process and applicants' responsibilities	20
4.2	Certificate Application Processing	22
4.2.1	Performance of identification and authentication procedures	22
4.2.2	Approval or rejection of certificate applications	22
4.2.3	Time limit for processing the certificate applications	22
4.3	Certificate Issuance	22
4.3.1	Actions performed by the CA during the issuance of the certificate.....	22
4.3.2	CA notification to the applicants of certificate issuance	22
4.4	Certificate Acceptance	22
4.4.1	Form of certificate acceptance	22
4.4.2	Publication of the certificate by the CA	22
4.4.3	Notification of certificate issuance by the CA to other Authorities	22
4.5	Key Pair and Certificate Usage	23
4.5.1	Certificate subscribers' use of the private key and certificate	23
4.5.2	Relying parties' use of the public key and the certificate	23
4.6	Certificate Renewal	23
4.7	Certificate Re-key	23
4.7.1	Circumstances for certificate renewal with key changeover	23
4.7.2	Who may request certificate renewal?	23
4.7.3	Procedures for processing certificate renewal requests with key changeover.....	23
4.7.4	Notification of the new certificate issuance to the subscriber	23
4.7.5	Manner of acceptance of certificates with changed keys	23
4.7.6	Publication of certificates with the new keys by the CA	23
4.7.7	Notification of certificate issuance by the CA to other Authorities	23
4.8	Certificate Modification	24
4.8.1	Circumstances for certificate modification	24
4.9	Certificate Revocation and Suspension	24
4.9.1	Circumstances for revocation.....	24
4.9.2	Who can request revocation?	24
4.9.3	Procedures for requesting certificate revocation	24
4.9.4	Revocation request grace period	24
4.9.5	Time limit for the CA to process the revocation request	24
4.9.6	Requirements for revocation verification by relying parties	24
4.9.7	CRL issuance frequency	24
4.9.8	Maximum latency between the generation of CRLs and their publication	25
4.9.9	Online certificate revocation status checking availability.....	25
4.9.10	Online revocation checking requirements.....	25
4.9.11	Other forms of revocation alerts available	25

4.9.12	Special requirements for the revocation of compromised keys.....	25
4.9.13	Causes for suspension.....	25
4.9.14	Who can request the suspension?.....	25
4.9.15	Procedure for requesting certificate suspension.....	25
4.9.16	Suspension period limits.....	25
4.10	Certificate Status Services.....	25
4.11	End of Subscription.....	25
4.12	Key Escrow and Recovery.....	26
5	<i>Facility, Management, and Operational Controls.....</i>	27
5.1	Physical Security Controls.....	27
5.2	Procedural Controls.....	27
5.3	Personnel Controls.....	27
5.4	Audit Logging Procedures.....	27
5.5	Records Archival.....	27
5.5.1	Types of records archived.....	27
5.5.2	Archive retention period.....	27
5.5.3	Archive protection.....	27
5.5.4	Archive backup procedures.....	27
5.5.5	Requirements for time-stamping records.....	27
5.5.6	Audit data archive system (internal vs. external).....	27
5.5.7	Procedures to obtain and verify archived information.....	27
5.6	Key Changeover.....	27
5.7	Compromise and Disaster Recovery.....	27
5.8	CA or RA Termination.....	27
6	<i>Technical Security Controls.....</i>	28
6.1	Key Pair Generation and Installation.....	28
6.1.1	Key pair generation.....	28
6.1.2	Delivery of private keys to subscribers.....	28
6.1.3	Delivery of the public key to the certificate issuer.....	28
6.1.4	Delivery of the CA's public key to relying parties.....	28
6.1.5	Key sizes.....	29
6.1.6	Public key generation parameters and quality checks.....	29
6.1.7	Key usage purposes (KeyUsage field in X.509 v3).....	29
6.2	Private Key Protection and Cryptographic Module Engineering Controls.....	29
6.2.1	Cryptographic module standards.....	29
6.2.2	Private key multi-person (k out of n) control.....	29
6.2.3	Escrow of private keys.....	29
6.2.4	Private key backup copy.....	29
6.2.5	Private key archive.....	29
6.2.6	Private key transfer into or from a cryptographic module.....	29
6.2.7	Private key storage in a cryptographic module.....	30

6.2.8	Private key activation method.....	30
6.2.9	Private key deactivation method.....	30
6.2.10	Private key destruction method.....	30
6.2.11	Cryptographic module classification.....	30
6.3	Other Aspects of Key Pair Management.....	30
6.3.1	Public key archive.....	30
6.3.2	Operational period of certificates and usage periods for key pairs.....	30
6.4	Activation Data.....	30
6.5	Computer Security Controls.....	30
6.6	Life Cycle Security Controls.....	30
6.7	Network Security Controls.....	31
6.8	Timestamping.....	31
7	<i>Certificate, CRL, and OCSP Profiles.....</i>	32
7.1	Certificate Profile.....	32
7.1.1	Version number.....	32
7.1.2	Certificate extensions.....	32
8.1.2	Algorithm Object Identifiers (OID).....	41
8.1.3	Name formats.....	41
8.1.4	Name constraints.....	41
8.1.5	Certificate Policy Object Identifiers (OID).....	41
8.1.6	Use of the "PolicyConstraints" extension.....	41
8.1.7	Syntax and semantics of the "PolicyQualifier".....	41
8.1.8	Processing semantics for the critical "CertificatePolicy" extension.....	41
8.2	CRL Profile.....	41
8.3	OCSP Profile.....	41
9	<i>Compliance Audit and Other Assessment.....</i>	42
10	<i>Other Business and Legal Matters.....</i>	43
10.1	Fees.....	43
10.1.1	Certificate issuance or renewal fees.....	43
10.1.2	Certificate access fees.....	43
10.1.3	Revocation or status information fees.....	43
10.1.4	Fees for other services, such as policy information.....	43
10.1.5	Refund policy.....	43
10.2	Financial Responsibility.....	43
10.3	Confidentiality of Business Information.....	43
10.3.1	Scope of confidential information.....	43
10.3.2	Non-confidential information.....	43
10.3.3	Duty to maintain professional secrecy.....	43
10.4	Privacy of Personal Information.....	43
10.4.1	Personal data protection policy.....	43
10.4.2	Information considered private.....	43

10.4.3	Information not classified as private	43
10.4.4	Responsibility to protect personal data	43
10.4.5	Notification of and consent to the use of personal data	43
10.4.6	Disclosure within legal proceedings	44
10.4.7	Other circumstances in which data may be made public	44
10.5	Intellectual Property Rights	44
10.6	Representations and Warranties.....	44
10.7	Disclaimers of Warranties	44
10.8	Limitations of Liability	44
10.9	Indemnities	44
10.10	Term and Termination.....	44
10.10.1	Term.....	44
10.10.2	CP substitution and termination	44
10.10.3	Consequences of termination	44
10.11	Individual notices and communications with participants	44
10.12	Amendments.....	44
10.13	Dispute Resolution Procedures.....	44
10.14	Governing Law	44
10.15	Compliance with Applicable Law	44
10.16	Miscellaneous Provisions	45
10.16.1	Entire agreement clause	45
10.16.2	Independence	45
10.16.3	Resolution through the courts	45
10.17	Other Provisions	45

Control Sheet

	Title	Certification Policy for the non-ESCB/non-SSM users' certificates
	Author	ESCB-PKI Service Provider
	Version	1.4
	Date	26.08.2019

RELEASE NOTES

In order to follow the current status of this document, the following matrix is provided. The numbers mentioned in the column "Release number" refer to the current version of the document.

Release number	Status	Date	Change Reason
0.1	Draft	27.05.2011	BdE revision
0.2	Draft	15.06.2011	BdE revision
0.3	Draft	14.07.2011	BdE revision
0.4	Draft	22.07.2011	BdE revision
0.5	Draft	26.07.2011	Add CA Fingerprint
0.6	Draft	15.09.2011	Revision of certificate profiles
1.0	Final	19.10.2011	Update after ITC approval.
1.1	Final	11.01.2013	GovC approval
1.2	Final	11.05.2015	Hashing algorithm update
1.3	Final	29.11.2018	<ul style="list-style-type: none"> • Key usage KeyEncipherment added to authentication certificate profile. • anyExtendedKeyUsage extended key usage removed in all certificate profiles. • Modifications to comply with Regulation N° 910/2014: <ul style="list-style-type: none"> ○ New extensions escbIssuerName and escbIssuerVAT are included to comply with Regulation (EU) No 910/2014. • Modifications to comply with ETSI EN 319 401: <ul style="list-style-type: none"> ○ Added a reference to the ESCB/SSM Information Systems Risk Management methodology ○ Added a reference to the ESCB/SSM Information Systems Security Policy ○ Added a statement to clarify that ESCB-PKI

			<p>services shall be provided in accordance with the principle of non-discrimination</p> <ul style="list-style-type: none"> ○ Added a statement to clarify that ESCB-PKI services shall be provided in accordance with the principle of non-discrimination ○ Added various statements to clarify relations with potential contractors ○ Updated chapters 1.3 and 5.2.1 to better clarify the ESCB-PKI role allocation procedures. ○ Updated the CA termination plan ○ Updated the Life-Cycle Security Controls ○ Other minor updates
1.4	Final	26.08.2019	Update after PKI-AB revision

1 Introduction

1.1 Overview

This document sets out the Certificate Policy (CP) governing the personal certificates issued to non-ESCB/non-SSM users (i.e. users that belong to organisations external to ESCB Central Banks and SSM National Competent Authorities) by the Public Key Infrastructure (hereinafter referred to as PKI) of the European System of Central Banks (hereinafter referred to as ESCB-PKI). It has been drafted in compliance with the **Decision ECB/2015/46**¹.

This document is intended for the use of all the participants related to the ESCB-PKI hierarchy, including the Certification Authority (CA), Registration Authorities (RA), certificate applicants, certificate subscribers and relying parties, among others.

From the perspective of the X.509 v3 standard, a CP is a set of rules that define the applicability or use of a certificate within a community of users, systems or specific class of applications that have a series of security requirements in common.

This CP details and completes the "Certification Practice Statement" (CPS) of the ESCB-PKI, containing the rules to which the use of the certificates defined in this policy are subject, as well as the scope of application and the technical characteristics of this type of certificate.

This CP has been structured in accordance with the guidelines of the PKIX work group in the IETF (Internet Engineering Task Force) in its reference document RFC 3647 (approved in November 2003) "Internet X.509 Public Key Infrastructure Certificate Policy and Certification Practices Framework". In order to give the document a uniform structure and facilitate its reading and analysis, all the sections established in RFC 3647 have been included. Where nothing has been established for any section the phrase "No stipulation" will appear. Furthermore, when drafting its content, European standards have been taken into consideration, among which the most significant are:

- ETSI EN 319 401: Electronic Signatures and Infrastructures (ESI); General Policy Requirements for Trust Service Providers.
- ETSI EN 319 411-1: Electronic Signatures and Infrastructures (ESI); Policy and security requirements for Trust Service Providers issuing certificates; Part 1: General requirements. This standard replaces ETSI TS 102 042: Policy Requirements for certification authorities issuing public key certificates.
- ETSI EN 319 411-2: Electronic Signatures and Infrastructures (ESI); Policy and security requirements for Trust Service Providers issuing certificates; Part 2: Requirements for trust service providers issuing EU qualified certificates. This standard replaces ETSI TS 101 456: Policy Requirements for certification authorities issuing qualified certificates.
- ETSI EN 319 412-1: Electronic Signatures and Infrastructures (ESI); Certificate Profiles; Part 1: Overview and common data structures
- ETSI EN 319 412-2: Electronic Signatures and Infrastructures (ESI); Certificate Profiles; Part 2: Certificate profile for certificates issued to natural persons
- ETSI EN 319 412-5: Electronic Signatures and Infrastructures (ESI); Certificate Profiles; Part 5: QCStatements. This standard replaces ETSI TS 101 862: Qualified Certificate Profile.

¹ Decision (EU) 2016/187 of the European Central Bank of 11 December 2015 amending Decision ECB/2013/1 laying down the framework for a public key infrastructure for the European System of Central Banks (ECB/2015/46).

Likewise, the following relevant legal framework has been considered:

- Decision ECB/2015/47²;
- General Data Protection Regulation³; Directive 1999/93/EC of the European Parliament and of the Council⁴; Regulation (EU) No 910/2014 of the European Parliament and of the Council⁵; Spanish Law 59/2003, of 19 December, the Electronic Signature Act (Spanish Official Journal, 20 December).⁶
- Regulation (EU) 2016/679 of the European Parliament and of the Council⁷; Spanish Organic Law 15/1999, of 13 December 1999, on the protection of personal data.
- Spanish Royal Decree 1720/2007, of 21 December 2007, approving the Regulations for the development of Spanish Organic Law 15/1999.
- National legislation transposing the General Data Protection Regulation and the Directive 99/93/EC applicable to the ESCB central banks and SSM national competent authorities acting as Registration Authorities.

This CP sets out the services policy, as well as a statement on the level of guarantee provided, by way of description of the technical and organisational measures established to guarantee the PKI's level of security.

The CP includes all the activities for managing the non-ESCB/non-SSM users' certificates throughout their life cycle, and serves as a guide for the relations between the Online CA and its users. Consequently, all the PKI participants (see section 1.3) involved must be aware of the content of the CP and adapt their activities to the stipulations therein.

This CP assumes that the reader is conversant with the PKI, certificate and electronic signature concepts. If not, readers are recommended to obtain information on the aforementioned concepts before they continue reading this document.

The general architecture, in hierarchic terms, of ESCB-PKI is as follows:

² Decision (EU) 2016/188 of the European Central Bank of 11 December 2015 on the access and use of SSM electronic applications, systems, platforms and services by the European Central Bank and the national competent authorities of the Single Supervisory Mechanism (ECB/2015/47).

³ Regulation (EU) 2016/679 of the European Parliament and of the Council of 27 April 2016 on the protection of natural persons with regard to the processing of personal data and on the free movement of such data, and repealing Directive 95/46/EC, OJ L 119, 4.5.2016, p. 1–88.

⁴ Directive 1999/93/EC of the European Parliament and of the Council of 13 December 1999 on a Community framework for electronic signatures (OJ L 13, 19.1.2000, p. 12).

⁵ Regulation (EU) No 910/2014 of the European Parliament and of the Council of 23 July 2014 on electronic identification and trust services for electronic transactions in the internal market (OJ L 257, 28.8.2014, p. 73).

⁶ Spanish legislation is also considered owed to the fact that Banco de España, the Service Provide, is established at Spain.

⁷ Regulation (EU) 2016/679 of the European Parliament and of the Council of 27 April 2016 on the protection of natural persons with regard to the processing of personal data and on the free movement of such data, and repealing Directive 95/46/EC.

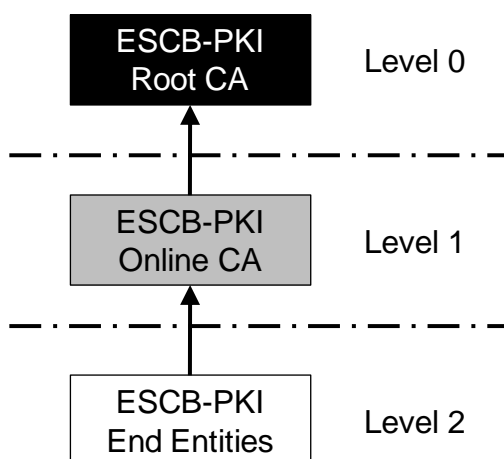

1.2 Document Name and Identification

Document name	Certificate Policy (CP) for the non-ESCB/non-SSM users' certificates
Document version	1.3
Document status	Final
Date of issue	29.11.2018
OID (Object Identifiers)	<p>0.4.0.127.0.10.1.2.3.0: Certificate policies for the non-ESCB/non-SSM users' certificates (this document)</p> <p>0.4.0.127.0.10.1.2.3.1: Certificate Policy of Advanced Authentication certificate for non-ESCB/non-SSM users</p> <p>0.4.0.127.0.10.1.2.3.2: Certificate Policy of Advanced Encryption certificate for non-ESCB/non-SSM users</p> <p>0.4.0.127.0.10.1.2.3.4: Certificate Policy of Advanced Signature certificate based on a SSCD for non-ESCB/non-SSM users</p> <p>0.4.0.127.0.10.1.2.3.5: Certificate Policy of Advanced Signature certificate for non-ESCB/non-SSM users</p> <p>0.4.0.127.0.10.1.2.3.6: Certificate Policy of Standard Authentication certificate for non-ESCB/non-SSM users</p>
CPS location	http://pki.escb.eu/policies
Related CPS	Certification Practice Statement of ESCB-PKI OID 0.4.0.127.0.10.1.2.1

1.3 ESCB-PKI Participants

As specified in the ESCB-PKI CPS.

1.3.1 The Policy Approval Authority

As specified in the ESCB-PKI CPS.

1.3.2 Certification Authority

As specified in the ESCB-PKI CPS.

1.3.3 Registration Authorities

As specified in the ESCB-PKI CPS.

1.3.3.1 Registration Authorities' roles

From the list of Registration Authorities' roles described in the CPS the ones required to manage ESCB/SSM users' certificates are the following:

- **Registration Officers for External Organisations**
- **Trusted Agents**

1.3.4 Validation Authority

As specified in the ESCB-PKI CPS.

1.3.5 Key Archive

No applicable.

1.3.6 Users

As specified in the ESCB-PKI CPS.

1.3.6.1 Certificate Subscribers

Certificate subscribers are defined in accordance with the ESCB-PKI CPS.

The categories of persons who may be certificate subscribers of non-ESCB/non-SSM users' certificates issued by the ESCB-PKI Online CA are limited to those included in the following chart:

Certification Authority	Certificate subscribers
Online CA	Users from non-ESCB/non-SSM organisations that need to communicate with ESCB/SSM applications (as non-ESCB/non-SSM users)

Certificate subscribers will be able to receive any of the following certificate packages:

- **Advanced certificates**, where all the following certificates will be stored in a smartcard or other cryptographic token (e.g. USB device):
 - Advanced authentication certificate. The corresponding key pair will be generated inside the cryptographic token.
 - Advanced signature certificate or advanced signature certificate based on a SSCD depending upon if the cryptographic token has got a SSCD certification or not. In both cases, the corresponding private key will be generated inside the cryptographic token.
 - Advanced encryption certificate without key archive. The key pair will be generated inside the cryptographic token and no other copy will be archived.

Standard certificates, where the private key will be generated by the CA and stored in a software device. The only type of standard certificate described in this CP is the authentication certificate.

1.3.6.2 Relying Parties

As specified in the ESCB-PKI CPS.

1.4 Certificate Usage

1.4.1 *Appropriate certificate use*

1 Certificates issued by ESCB-PKI in the scope of this CP may only be used within the scope of the ESCB/SSM by users from external organisations.

2 Within the scope of the paragraph above, certificates issued by ESCB-PKI may be used for financial activities.

The certificates regulated by this CP shall be used for personal authentication, signing and/or encryption purposes, depending on the corresponding keyUsage extension and OID attribute in the *certificatePolicies* extension.

1.4.2 *Certificate Usage Constraints and Restrictions*

Any other use not included in the previous point shall be excluded.

1.5 Policy Approval

As specified in the ESCB-PKI CPS.

1.6 Definitions and Acronyms

1.6.1 *Definitions*

Within the scope of this CPS the following terms are used:

Authentication: the process of confirming the identity of a certificate subscriber.

Identification: the process of verifying the identity of those applying for a certificate.

Eurosystem Central Bank: means either an NCB of a Member State whose currency is the euro or the ECB.

Non-euro area NCB: means an NCB of a Member State whose currency is not the euro.

ESCB Central Bank: means either a Eurosystem Central Bank or a non-euro area NCB.

Central Bank: In this CP the term "Central Bank" is used to refer to any Central Bank belonging to the European System of Central Banks/Eurosystem, including the ECB.

National Competent Authority or SSM National Competent Authority: means any National Competent Authority (NCA) belonging to the Single Supervisory Mechanism (SSM) that has agreed to use the ESCB-PKI.

External or non-ESCB/non-SSM Organisation: public or private organisation that do not belong to the European System of Central Banks (ESCB) or to the Single Supervisory Mechanism (SSM).

Non-ESCB/non-SSM user: user that belongs to a non-ESCB/non-SSM organisation.

Electronic certificate or certificate: electronic file, issued by a certification authority, that binds a public key with a certificate subscriber's identity and is used for the following: to verify that a public key belongs to a certificate subscriber; to authenticate a certificate subscriber; to check a certificate's subscriber signature; to encrypt a message addressed to a certificate subscriber; or to verify a certificate subscriber's access rights to ESCB/SSM electronic applications, systems, platforms and services. Certificates are held on data carrier devices, and references to certificates include such devices.

Public key and private key: the asymmetric cryptography on which the PKI is based employs a key pair in which what is enciphered with one key of this pair can only be deciphered by the other, and vice versa. One of these keys is "public" and is included in the electronic certificate, whilst the other is "private" and is only known by the certificate subscriber.

Session key: a key established to encipher communication between two entities. The key is established specifically for each communication, or session, and its utility expires upon termination of the session.

Key agreement: a process used by two or more technical components to agree on a session key in order to protect a communication.

Directory: a data repository that is usually accessed through the LDAP protocol.

User identifier: a set of characters that are used to uniquely identify the user of a system.

Public Key Infrastructure: the set of individuals, policies, procedures, and computer systems necessary to provide authentication, encryption, integrity and non-repudiation services, by way of public and private key cryptography and electronic certificates.

ESCB-PKI Certification Authority: means the entity, trusted by users, to issue, manage, revoke and renew certificates in accordance with the ESCB certificate acceptance framework.

Trust hierarchy: the set of Certification Authorities that maintain a relationship of trust by which a CA of a higher level guarantees the trustworthiness of one or several lower level CAs. In the case of ESCB-PKI, the hierarchy has two levels: the Root CA at the top level guarantees the trustworthiness of its subordinate CAs, one of which is the Online CA.

Certification Service Provider (CSP): entity or a legal or natural person who issues certificates or provides other services related to electronic signatures.

Registration Authority: means an entity trusted by the users of the certification services which verifies the identity of individuals applying for a certificate before the issuance of the certificate by the ESCB-PKI Certification Authority.

Certificate applicants: the individuals who request the issuance of certificates.

Certificate subscribers: the individuals for which an electronic certificate is issued and accepted by said individuals.

Relying parties: individuals or entities, other than certificate subscribers, that decide to accept and rely on a certificate issued by ESCB-PKI.

Providing Central Bank or service provider: means the NCB appointed by the Governing Council to develop the ESCB-PKI and to issue, manage, revoke and renew electronic certificates on behalf and for the benefit of the Eurosystem central banks.

Repository: a part of the content of the ESCB-PKI website where relying parties, certificate subscribers and the general public can obtain copies of ESCB-PKI documents, including but not limited to this CP and CRLs.

Validation Authority: means an entity trusted by the users of the certification services which provides information about the revocation status of the certificates issued by the ESCB-PKI Certification Authority.

1.6.2 Acronyms

C: (Country). Distinguished Name (DN) attribute of an object within the X.500 directory structure

CA: Certification Authority

CAF: Certificate Acceptance Framework

CB: Central Bank that uses the ESCB-PKI

CDP: CRL Distribution Point

CEN: Comité Européen de Normalisation

CN: Common Name Distinguished Name (DN) attribute of an object within the X.500 directory structure

CP: Certificate Policy

CPS: Certification Practice Statement

CRL: Certificate Revocation List

CSP: Certification Service Provider

CSR: Certificate Signing Request: set of data that contains the public key and its electronic signature using the companion private key, sent to the CA for the issue of an electronic signature that contains said public key

CWA: CEN Workshop Agreement

DN: Distinguished Name: unique identification of an entry within the X.500 directory structure

ECB: European Central Bank

ESCB: European System of Central Banks

ESCB-PKI: European System of Central Banks Public Key Infrastructure: means the public key infrastructure developed by the providing central bank on behalf of and for the benefit of the Eurosystem Central Banks which issues, manages, revokes and renews certificates in accordance with the ESCB certificate acceptance framework - as amended from time to time including in relation to SSM.

ETSI: European Telecommunications Standard Institute

FIPS: Federal Information Processing Standard

HSM: Hardware Security Module: cryptographic security module used to store keys and carry out secure cryptographic operations

IAM: Identity and Access Management

IETF: Internet Engineering Task Force (internet standardisation organisation)

ITC: Information Technology Committee

LDAP: Lightweight Directory Access Protocol

NCA: National Competent Authority

NCB: National Central Bank

O: Organisation. Distinguished Name (DN) attribute of an object within the X.500 directory structure

OCSP: Online Certificate Status Protocol: this protocol enables online verification of the validity of an electronic certificate

OID: Object Identifier

OU: Organisational Unit. Distinguished Name (DN) attribute of an object within the X.500 directory structure

PAA: Policy Approval Authority

PIN: Personal Identification Number: password that protects access to a cryptographic card

PKCS: Public Key Cryptography Standards: internationally accepted PKI standards developed by RSA Laboratories

PKI: Public Key Infrastructure

PKIX: Work group within the IETF (Internet Engineering Task Group) set up for the purpose of developing PKI and internet specifications

PUK: PIN Unlock Code: password used to unblock a cryptographic card that has been blocked after repeatedly and consecutively entering the wrong PIN

RA: Registration Authority

RO: Registration Officer

RO4EO: Registration Officer for External Organisations

RFC: Request For Comments (Standard issued by the IETF)

SSCD: Secure Signature Creation Device

SSM: Single Supervisory Mechanism

T&C: Terms and conditions application form

UID: User identifier

VA: Validation Authority

2 Publication and Repository Responsibilities

2.1 Repositories

As specified in the ESCB-PKI CPS.

2.2 Publication of Certification Data, CPS and CP

As specified in the ESCB-PKI CPS.

Moreover, a copy of the non-ESCB/non-SSM users' certificates is published in the directory of the ESCB Identity and Access Management (IAM) service.

2.3 Publication Timescale or Frequency

As specified in the ESCB-PKI CPS.

2.4 Repository Access Controls

As specified in the ESCB-PKI CPS.

3 Identification and Authentication (I&A)

3.1 Naming

3.1.1 Types of names

The certificates issued by ESCB-PKI contain the Distinguished Name (or DN) X.500 of the issuer and that of the certificate subject in the fields *issuer name* and *subject name*, respectively.

The CN (Common Name) attribute of the DN contains a prefix that identifies the certificate usage, and the following are accepted:

- [AUT:S] → Standard Authentication certificate
- [AUT:A] → Advanced Authentication certificate
- [SIG:A] → Advanced Signature certificate based on a token without SSCD certification
- [SIG:Q] → Advanced Signature certificate based on a token with SSCD certification
- [ENC:A] → Advanced Encryption certificate without private key archive

This prefix will be followed by the name, middle name and surnames of the certificate subscribers.

Additionally, the following field is used:

- PS (OID: 2.5.4.65)= <User identifier at ESCB/SSM level>

The rest of the DN attributes shall have the following fixed values:

- C [Country where the Registration Authority is located]
- O EUROPEAN SYSTEM OF CENTRAL BANKS
- OU Non-ESCB/non-SSM organisation to which the subscriber belongs to

3.1.2 The need for names to be meaningful

In all cases the distinguished names of the certificates are meaningful because they are subject to the rules established in the previous point in this respect.

3.1.3 Rules for interpreting various name formats

As specified in the ESCB-PKI CPS.

3.1.4 Uniqueness of names

The whole made up of the combination of the distinguished name plus the KeyUsage extension content must be unique and unambiguous to ensure that certificates issued for two different certificate subscribers will have different distinguished names.

Certificate DNs must not be repeated. The use of the user identifier at ESCB/SSM level guarantees the uniqueness of the DN.

3.1.5 Name dispute resolution procedures

As specified in the ESCB-PKI CPS.

3.1.6 Recognition, authentication, and the role of trademarks

As specified in the ESCB-PKI CPS.

3.2 Initial Identity Validation

3.2.1 Means of proof of possession of the private key

Depending on the specific certificate type, the means of proof of private key possession will be different:

- [AUT:S] → standard authentication certificate: the key pair will be created by the ESCB-PKI Online Certification Authority, so this section does not apply.
- [AUT:A] → advanced authentication certificate: the key pair will be created by the subject in the private zone into his cryptographic token and the public key will be provided to the ESCB-PKI Online CA for its certification.

- [SIG:A] → advanced signature certificate (no SSCD token): the key pair will be created by the subject in the private zone into his cryptographic token and the public key will be provided to the ESCB-PKI Online CA for its certification.
- [SIG:Q] → advanced Signature certificate based on a SSCD token: the key pair will be created by the subject in the SSCD zone of a secure signature creation device and the public key will be provided to the ESCB-PKI Online CA for its certification.
- [ENC:A] → advanced encryption without key archive: the key pair will be created by the subject in the private zone into his secure signature creation device and the public key will be provided to the ESCB-PKI Online CA for its certification.

3.2.2 Identity authentication for an entity

This CP does not consider the issuance of certificates for entities.

3.2.3 Identity authentication for an individual

Evidence of the subject's identity is checked against a physical person.

Validation of the individual

Unless the certificate applicant has already been identified previously by the Central Bank or National Competent Authority acting as Registration Authority through a face-to-face identification process with the same requirements, the certificate applicant shall provide evidences of, at least, the following information:

- Full name, and
- Date and place of birth, or reference to a nationally recognized identity document, or other attributes which may be used to distinguish the person from others with the same name.

To validate the previous information the certificate applicant must present a document as proof of identity. The acceptable documents are:

- Passport, or
- National Identity Card, or
- Any other legal document accepted by the legislation applicable to the Central Bank or National Competent Authority acting as Registration Authority to fully identify an individual.

The validation of the identity will be performed by a Registration Officer for External Organisations or by a Trusted Agent delegated at the external organisation.

Validation of the non-ESCB/non-SSM organisation

Unless the non-ESCB/non-SSM organisation to which the certificate applicant belongs has already been validated previously by the Central Bank or National Competent Authority through a process with the same requirements, the following information must be provided:

1. To validate the non-ESCB/non-SSM organisation:
 - Recent constitutive act of the non-ESCB/non-SSM organisation, or
 - Recent extract of the national commercial register, or
 - Any equivalent document accepted by the applicable national legislation to duly identify an Organisation, and

2. To prove the applicant's relations with the non-ESCB/non-SSM organisation
 - An authorisation of one of the physical persons who are a legal representative of the non-ESCB/non-SSM organisation, to request non-ESCB/non-SSM users' certificates to be used in the communication between the ESCB/SSM and the Organisation
 - A copy of the identity evidence (National Identity card, Passport or any other legal document accepted by the applicable national legislation) of the physical person who is the legal representative of the Organisation; in case this person cannot be physically present, the copy must be certified by a competent authority according to the national legislation.

3.2.4 Non-verified applicant information

All the information stated in the previous section must be verified.

3.2.5 Validation of authority

As specified in the ESCB-PKI CPS.

3.2.6 Criteria for operating with external CAs

As specified in the ESCB-PKI CPS.

3.3 Identification and Authentication for Re-key Requests**3.3.1 Identification and authentication requirements for routine re-key**

The same process as for initial identity validation is used.

3.3.2 Identification and authentication requirements for re-key after certificate revocation

The same process as for initial identity validation is used.

4 Certificate Life-Cycle Operational Requirements

This chapter contains the operational requirements for the life cycle of non-ESCB/non-SSM users' certificates issued by the ESCB-PKI CA. Despite the fact that these certificates might be stored on cryptographic tokens, it is not the purpose of the Certificate Policy to regulate the management of said tokens and, therefore, it is also assumed that the certificate applicants have previously obtained their cryptographic tokens.

4.1 Certificate Application

4.1.1 Who can submit a certificate application?

Certificates for non-ESCB/non-SSM users will be managed by a Registration Officer for External Organisations (RO4EO). RO4EOs will be able to request certificate types mentioned in section 1.3.6.

Application for a certificate does not mean it will be obtained if the applicant does not fulfil the requirements established in the CPS or in this CP for non-ESCB/non-SSM users' certificates (e.g. if the certificate applicant does not provide the RO4EO with the documents necessary for his/her identification)

4.1.2 Enrolment process and applicants' responsibilities

Advanced certificates (cryptographic token-based)

This process is carried out to obtain a certificate package consisting on three certificates: authentication, encryption and signature certificates. The certificate package will be stored in a cryptographic token. The procedure is the same independently on the type of token (with or without SSCD certification) to be used.

The procedure is as follows:

1. Cryptographic token-based certificate requests for a non-ESCB/non-SSM user can be initiated:
 - a. either using ESCB Identity Access Management (IAM) interfaces,
 - b. or using ESCB-PKI web interface;
2. The certificate applicant must explicitly accept the terms and conditions application form (T&C) by his/her hand-written signature of the term and conditions. The T&C will incorporate the following data:
 - a. the attributes to be included in the certificate: first name, middle name (if any), surname, name of the organisation that the user belongs to, user identifier and e-mail address;
 - b. the serial number of the certificate applicant's cryptographic token;
 - c. under the conditions and limitations of the applicable data protection law, central banks may require that the certificate applicant provides on the T&C the attributes required to distinguish the person from others with the same name (see Section 3.2.3), namely, the number of a national recognized identity document according to the legislation applicable to the Central Bank or National Competent Authority acting as Registration Authority, or the date and place of birth.
3. In the case that a Trusted Agent is in charge of identifying and authenticating the certificate applicant, he/she will add his/her hand-written signature to the T&C;
4. The RO4EO must validate the information included in the certificate request against the documentation provided by the certificate applicant, including the T&C. In the case that the certificate applicant is not in front of him/her, the RO4EO will also validate that a valid Trusted Agent has signed the T&C;
5. The RO4EO, using the ESCB-PKI web interface, will either:

- a. Start the issuance of certificates
- b. Approve a remote download

In both cases the certificate applicant must hold his/her token and, when requested, must insert it and type his/her personal PIN to generate the keys and store the certificates,

6. The RO4EO must securely archive all the documentation during the retention period described in section 5.5.2 of this CP:
 - a. the terms and conditions application form signed by both, the certificate applicant and the person who identified and authenticated him/her (i.e. the Trusted Agent or the RO4EO himself/herself)
 - b. under the conditions and limitations of the applicable data protection law, the central bank may choose to ask their RO4EO to retain a copy of the official identification document used to validate the certificate applicant's identity or, if this were not legally feasible, a copy of other identification document, preferable with the certificate applicant's photography;

Standard certificates (software-based)

This process is carried out to obtain a single certificate valid for authentication that will be stored in a software keystore (i.e. a password protected file).

The procedure is as follows:

1. Software-based certificate requests for a non-ESCB/non-SSM user can be initiated:
 - a. either using ESCB Identity Access Management (IAM) interfaces,
 - b. or using ESCB-PKI web interface;
2. The certificate applicant must explicitly accept the terms and conditions application form (T&C) by his/her hand-written signature of the terms and conditions. The T&C will incorporate the following data:
 - a. the attributes to be included in the certificate: first name, middle name (if any), surname, name of the organisation that the user belongs to, user identifier and e-mail address;
 - b. under the conditions and limitations of the applicable data protection law, central banks may require that certificate applicant provides on the T&C the attributes required to distinguish the person from others with the same name (see Section 3.2.3), namely, the number of a national recognized identity document, according to the legislation applicable to the Central Bank or National Competent Authority acting as Registration Authority, or the date and place of birth.
3. In the case that a Trusted Agent is in charge of identifying and authenticating the certificate applicant, he/she will add his/her hand-written signature to the T&C;
4. The RO4EO must validate the information included in the certificate request against the documentation provided by the certificate applicant, including the T&C. In the case that the certificate applicant is not in front of him/her, the RO4EO will also validate that a valid Trusted Agent has signed the T&C;
5. The RO4EO, using the ESCB-PKI web interface, will either:
 - a. Start the issuance of the certificate.
 - b. Approve a remote download

In both cases the certificate applicant will be requested to type a password to protect the keystore (file) to be generated with the certificate and its corresponding private key;

6. The RO4EO must securely archive all the documentation during the retention period described in section 5.5.2 of this CP:
 - a. the terms and conditions application form signed by both, the certificate applicant and the person who identified and authenticated him/her (i.e. the Trusted Agent or the RO4EO himself/herself)
 - b. under the conditions and limitations of the applicable data protection law, the Central Bank or National Competent Authority may choose to ask their RO4EO to retain a copy of the official identification document used to validate the certificate applicant's identity or, if this were not legally feasible, a copy of other identification document, preferable with the certificate applicant's photography;

4.2 Certificate Application Processing

4.2.1 Performance of identification and authentication procedures

The validation of certificate requests will require face-to-face authentication of the certificate applicant or using means which provide equivalent assurance to physical presence.

The Registration Officer for External Organisations or a Trusted Agent will perform the certificate applicant's identification and authentication and will ensure that all the information provided is correct at the time of registration. The identification and authentication process will be done as specified in section 3.2.3 of this CP.

4.2.2 Approval or rejection of certificate applications

As specified in the ESCB-PKI CPS.

4.2.3 Time limit for processing the certificate applications

The Certification Authority shall not be held liable for any delays that may arise in the period between application for the certificate, publication in the ESCB-PKI repository and its delivery. As far as possible, the Certification Authority will process requests within 24 hours.

4.3 Certificate Issuance

4.3.1 Actions performed by the CA during the issuance of the certificate

As specified in the ESCB-PKI CPS.

4.3.2 CA notification to the applicants of certificate issuance

Applicants will be advised of the availability of the certificates via e-mail.

4.4 Certificate Acceptance

4.4.1 Form of certificate acceptance

Certificate applicants must confirm acceptance of the non-ESCB/non-SSM users' certificates and of its conditions by way of a hand-written signature of the terms and conditions application form.

4.4.2 Publication of the certificate by the CA

The ESCB-PKI CA publishes a copy of the non-ESCB/non-SSM user's certificates: i) in an internal LDAP directory located at the service provider's premises, only available to ESCB/SSM systems on a need-to-know basis, and ii) in the directory of the ESCB Identity and Access Management (IAM) service.

4.4.3 Notification of certificate issuance by the CA to other Authorities

Not applicable.

4.5 Key Pair and Certificate Usage

4.5.1 *Certificate subscribers' use of the private key and certificate*

The certificates regulated by this CP may be used only to provide the following security services:

- Authentication certificates: authentication against ESCB/SSM applications.
- Encryption certificates: encryption of email messages and files.
- Signature certificates: digital signature of transactions, email messages and files.

4.5.2 *Relying parties' use of the public key and the certificate*

As specified in ESCB-PKI CPS.

4.6 Certificate Renewal

As specified in ESCB-PKI CPS.

4.7 Certificate Re-key

4.7.1 *Circumstances for certificate renewal with key changeover*

As specified in ESCB-PKI CPS.

4.7.2 *Who may request certificate renewal?*

Renewals must be requested by certificate subscribers.

4.7.3 *Procedures for processing certificate renewal requests with key changeover*

During the renewal process, the RO4EO will check that the information used to verify the identity and attributes of the certificate subscriber is still valid. If any of the certificate subscriber's data have changed, they must be verified and registered with the agreement of the certificate subscriber.

If any of the conditions established in this CP have changed, the certificate subscriber must be made aware of this and agree to it.

In any case, certificate renewal is subject to:

- Renewal must be requested in person at the places of registration, as established for initial issuance, as established in 4.1.2.
- Renewal of certificates may only be requested within the last 100 days of its lifetime.
- The CA not having certain knowledge of the existence of any cause for the revocation / suspension of the certificate.
- The request for the renewal of the provision of services being for the same type of certificate as the one initially issued.

4.7.4 *Notification of the new certificate issuance to the subscriber*

They are notified by e-mail.

4.7.5 *Manner of acceptance of certificates with changed keys*

As in the initial certificate issuance, they must sign the terms and conditions application form as a manner of acceptance of the certificates.

4.7.6 *Publication of certificates with the new keys by the CA*

The ESCB-PKI CA publishes a copy of the non-ESCB/non-SSM user's certificates: i) in an internal LDAP directory located at the service provider's premises, only available to ESCB/SSM systems on a need-to-know basis, and ii) in the directory of the ESCB Identity and Access Management (IAM) service.

4.7.7 *Notification of certificate issuance by the CA to other Authorities*

As specified in the ESCB-PKI CPS.

4.8 Certificate Modification

4.8.1 Circumstances for certificate modification

As specified in ESCB-PKI CPS.

4.9 Certificate Revocation and Suspension

4.9.1 Circumstances for revocation

As specified in ESCB-PKI CPS.

Additionally, revoked ESCB/SSM users' certificates will be eliminated from the directories in which they are published.

4.9.2 Who can request revocation?

The CA or any of the RAs may, of their own initiative, request the revocation of a certificate if they become aware or suspect that the certificate subscriber's private key has been compromised, or in the event of any other factor that recommends taking such action.

Likewise, certificate subscribers may also request revocation of their certificates, which they must do in accordance with the conditions established under point 4.9.3.

The identification policy for revocation requests will be the same as that of the initial registration.

4.9.3 Procedures for requesting certificate revocation

The certificate subscribers or individuals requesting the revocation must appear before the RO4EO, identifying themselves and indicating the reason for the request.

The RO4EO shall always process the revocation requests submitted by its assigned subscribers. The request is made via an authenticated web Interface.

Apart from this ordinary procedure, PKI System registration officers may immediately revoke any certificate upon becoming aware of the existence of any of the causes for revocation.

4.9.4 Revocation request grace period

As specified in ESCB-PKI CPS.

4.9.5 Time limit for the CA to process the revocation request

Requests for revocation of certificates must be processed as quickly as possible, and in no case may said processing take more than 1 hour.

4.9.6 Requirements for revocation verification by relying parties

Verification of revocations, whether by directly consulting the CRL or using the OCSP protocol, is mandatory for each use of the certificates by relying parties.

Relying parties must check the validity of the CRL prior to each use and download the new CRL from the ESCB-PKI repository when the one they hold expires. CRLs stored in cache⁸ memory, even when not expired, do not guarantee availability of updated revocation data.

For non-ESCB/non-SSM users' certificates, the ordinary validity verification procedure for a certificate shall be carried out with the ESCB-PKI Validation Authority, which shall indicate, through the OCSP protocol, the status of the certificate.

4.9.7 CRL issuance frequency

As specified in ESCB-PKI CPS.

⁸Cache memory: memory that stores the necessary data for the system to operate faster, as it does not have to obtain this data from the source for every operation. Its use could entail the risk of operating with outdated data.

4.9.8 Maximum latency between the generation of CRLs and their publication

The maximum time allowed between generation of the CRLs and their publication in the repository is 1 hour.

4.9.9 Online certificate revocation status checking availability

As specified in ESCB-PKI CPS.

4.9.10 Online revocation checking requirements

As specified in ESCB-PKI CPS.

4.9.11 Other forms of revocation alerts available

No stipulation.

4.9.12 Special requirements for the revocation of compromised keys

As specified in ESCB-PKI CPS.

4.9.13 Causes for suspension

Certificate suspension is the action that renders a certificate invalid for a period of time prior to its expiry date. Certificate suspension produces the discontinuance of the certificate's validity for a limited period of time, rendering it inoperative as regards its inherent uses and, therefore, discontinuance of the provision of certification services. Suspension of a certificate prevents its legitimate use by the subscriber.

Suspension of a certificate entails its publication on the public-access Certificate Revocation Lists (CRL). The main effect of suspension as regards the certificate is that certificates become invalid until they are again reactivated. Suspension shall not affect the underlying obligations created or notified by this CP, nor shall its effects be retroactive.

Non-ESCB/non-SSM users' certificates may be suspended due to:

- Certificate subscriber's request, under suspicion of key compromise.

4.9.14 Who can request the suspension?

The subscribers of Non-ESCB/non-SSM users' certificates and Registration Officers for External Organisations.

4.9.15 Procedure for requesting certificate suspension

Certificate subscribers may immediately suspend his certificates via an authenticated Web Interface. Access will be granted by means of by means of one of the following mechanisms:

- an authentication certificate;
- an user ID and password for the ESCB Identity and Access Management (IAM) system;
- a suspension code (secret shared with the ESCB-PKI system)

4.9.16 Suspension period limits

The CA shall ensure that a certificate is not kept suspended for longer than is necessary to confirm its status.

Revocation will be processed immediately after receiving the certificate subscriber confirmation for revocation (see 4.9).

4.10 Certificate Status Services

As specified in ESCB-PKI CPS.

4.11 End of Subscription

As specified in ESCB-PKI CPS.

4.12 Key Escrow and Recovery

Not applicable.

5 Facility, Management, and Operational Controls

5.1 Physical Security Controls

As specified in the ESCB-PKI CPS.

5.2 Procedural Controls

As specified in the ESCB-PKI CPS.

5.3 Personnel Controls

As specified in the ESCB-PKI CPS.

5.4 Audit Logging Procedures

As specified in the ESCB-PKI CPS.

5.5 Records Archival

5.5.1 Types of records archived

As specified in the ESCB-PKI CPS.

5.5.2 Archive retention period

The retention period for records related to non-ESCB/non-SSM users' certificates is 15 years, which is the legally mandated period according to the Spanish legislation.

5.5.3 Archive protection

As specified in the ESCB-PKI CPS.

5.5.4 Archive backup procedures

As specified in the ESCB-PKI CPS.

5.5.5 Requirements for time-stamping records

As specified in the ESCB-PKI CPS.

5.5.6 Audit data archive system (internal vs. external)

As specified in the ESCB-PKI CPS.

5.5.7 Procedures to obtain and verify archived information

As specified in the ESCB-PKI CPS.

5.6 Key Changeover

As specified in the ESCB-PKI CPS.

5.7 Compromise and Disaster Recovery

As specified in the ESCB-PKI CPS.

5.8 CA or RA Termination

As specified in the ESCB-PKI CPS.

6 Technical Security Controls

Technical security controls for internal ESCB-PKI components, and specifically those controls for Root CA and Online CA, during certificate issue and certificate signature processes, are described in the ESCB-PKI CPS.

In this paragraph technical security controls for the issuance of certificates under this CP are covered.

6.1 Key Pair Generation and Installation

6.1.1 Key pair generation

Keys for non-ESCB/non-SSM users' certificates issued by the Online CA are generated under the following circumstances, depending on the certificate type:

- **Advanced certificates**, where all the following certificates will be stored in a smartcard or other cryptographic token:
 - Advanced authentication certificate. The corresponding key pair will be generated inside the cryptographic token pursuant to the FIPS 140-2 Level 3 or CC EAL4+ specification or equivalent.
 - Advanced signature certificate. The corresponding private key will be generated inside the cryptographic token pursuant to the FIPS 140-2 Level 3 or CC EAL4+ specification or equivalent.
 - Advanced signature certificate based on a SSCD. The corresponding private key will be generated inside the cryptographic token pursuant to the FIPS 140-2 Level 3 or CC EAL4+ specification or equivalent and to the SSCD (CWA 14169) specification.
 - Advanced encryption certificate without key archive. The key pair will be generated inside the cryptographic token pursuant to the FIPS 140-2 Level 3 or CC EAL4+ specification or equivalent, and no other copy will be archived.
- **Standard certificates**, where the private key will be generated by the ESCB-PKI Online CA, using a cryptographic module pursuant to the FIPS 140-2 level 3 specification.

6.1.2 Delivery of private keys to subscribers

6.1.2.1 Advanced certificates

The private keys will be generated directly by the subscribers in their secure token and, therefore, no delivery is required.

6.1.2.2 Standard certificates

For standard certificates, the delivery of the private key to the certificate subscriber will be performed by means of an authenticated web interface. The certificate subscriber will receive the key pair in a file pursuant to the PKCS#12 specification protected with a password selected by him/her.

6.1.3 Delivery of the public key to the certificate issuer

In case of standard authentication certificates, public keys are generated by the ESCB-PKI Online CA, and therefore delivery to the certificate issuer is not applicable.

In the other cases, the public keys are generated by certificate subscribers on their cryptographic tokens and then delivered to the ESCB-PKI Online CA within the process required to obtain the certificate.

6.1.4 Delivery of the CA's public key to relying parties

The ESCB-PKI Online CA public key is included in the certificate of that CA. The ESCB-PKI Online CA certificate is not included in the certificate generated by the certificate subscriber. The ESCB-PKI Online CA certificate must be obtained from the repository specified in this document where it is available by certificate subscribers and relying parties to carry out any type of verification.

6.1.5 Key sizes

The key size of any non-ESCB/non-SSM users' certificate is 2048 bits.

6.1.6 Public key generation parameters and quality checks

Public keys are encoded pursuant to RFC 3280 and PKCS#1. The key generation algorithm is the RSA.

6.1.7 Key usage purposes (KeyUsage field in X.509 v3)

The 'Key Usage' and 'Extended Key Usage' fields of the certificates included in this CP are described in the 7.1.1.2.

6.2 Private Key Protection and Cryptographic Module Engineering Controls

6.2.1 Cryptographic module standards

The Hardware Security Module (HSM) used for the creation of keys used by ESCB-PKI Online CA is pursuant to FIPS 140-2 Level 3.

Start-up of each one of the Certification Authorities, taking into account that a HSM is used, involves the following tasks:

- a HSM module status boot up.
- b Creation of administration and operator cards.
- c Generation of the CA keys.

As regards the cryptographic token, they will be pursuant to the FIPS 140-2 level 3 or CC EAL4+ specification or equivalent. In the case of advanced signature certificates based on a SSCD, they will be also pursuant to the SSCD specification (CWA 14169).

6.2.2 Private key multi-person (k out of n) control

The private key, both for Root CA as for Subordinate CA, is under multi-person control; its activation is done through CA software initialisation by means of a combination of CA and HSM operators. This is the only activation method for said private key.

There is no multi-person control established for accessing the private keys of the certificates issued under this CP.

6.2.3 Escrow of private keys

Not applicable

6.2.4 Private key backup copy

Advanced certificates

The certificate subscribers cannot backup their certificates because the keys cannot be exported outside of the cards and these cannot be cloned.

Standard certificates

The certificate subscribers will have to keep the PKCS#12 file and corresponding protection password as a backup copy.

6.2.5 Private key archive

Advanced certificates

The private keys are generated on cryptographic cards, they are not exported under any circumstances, and access to operations with said cards is protected by a PIN code.

Standard certificates

ESCB-PKI will not keep any archive of the private key associated to standard certificates.

6.2.6 Private key transfer into or from a cryptographic module

Advanced certificates

Provided that the private key is generated inside the cryptographic token there is no transmission of this key to or from any cryptographic module.

Standard certificates

No stipulated

6.2.7 Private key storage in a cryptographic module**Advanced certificates**

Private keys are created on the cryptographic token and are stored there

Standard certificates

Private keys are created in the ESCB-PKI Online CA's cryptographic module, but they are not subsequently saved.

6.2.8 Private key activation method**Advanced certificates**

Private keys are stored in a cryptographic token protected with a PIN code that is required to activate the keys.

Standard certificates

Private keys are delivered in a PKCS#12 file, protected by a password. The password is required to activate the private key.

6.2.9 Private key deactivation method**Advanced certificates**

Private keys can be deactivated by removing the card from the reader.

Standard certificates

No stipulation.

6.2.10 Private key destruction method**Advanced certificates**

Private keys can be destroyed by destroying the cryptographic token.

Standard certificates

No stipulation.

6.2.11 Cryptographic module classification

The cryptographic modules used by ESCB-PKI technical components comply with the FIPS 140-2 Level 3 standard.

6.3 Other Aspects of Key Pair Management**6.3.1 Public key archive**

As specified in the ESCB-PKI CPS.

6.3.2 Operational period of certificates and usage periods for key pairs

All certificates and their linked key pair have a lifetime of 3 years, although the ESCB-PKI Online CA may establish a shorter period at the time of their issue.

6.4 Activation Data

As specified in the ESCB-PKI CPS.

6.5 Computer Security Controls

As specified in the ESCB-PKI CPS.

6.6 Life Cycle Security Controls

As specified in the ESCB-PKI CPS.

6.7 Network Security Controls

As specified in the ESCB-PKI CPS.

6.8 Timestamping

As specified in the ESCB-PKI CPS.

7 Certificate, CRL, and OCSP Profiles

7.1 Certificate Profile

7.1.1 Version number

Certificates for the non-ESCB/non-SSM users are compliant with the X.509 version 3 (X.509 v3) standard.

7.1.2 Certificate extensions

The certificate extensions used generically are:

- *Subject Key Identifier*. Classified as non-critical.
- *Authority Key Identifier*. Classified as non-critical.
- *KeyUsage*. Classified as critical.
- *extKeyUsage*. Classified as non-critical.
- *CertificatePolicies*. Classified as non-critical.
- *SubjectAlternativeName*. Classified as non-critical.
- *BasicConstraints*. Classified as critical.
- *CRLDistributionPoint*. Classified as non-critical.
- *Auth. Information Access*. Classified as non-critical.
- *escbUseCertType (0.4.0.127.0.10.1.3.1)*. Classified as non-critical.
- *escbIssuerName (0.4.0.127.0.10.1.3.2)*. Classified as non-critical.
- *escbIssuerVAT (0.4.0.127.0.10.1.3.3)*. Classified as non-critical.

For understanding purposes, all ESCB-PKI OID attributes references are made under the [OID ESCBPKI] mark, which corresponds to 0.4.0.127.0.10.1.

7.1.2.1 Advanced authentication certificate

Advanced authentication certificate		
Field	Value	Critical
Base Certificate		
Version	3	
Serial Number	<i>Random</i>	
Signature Algorithm	SHA1-WithRSAEncryption (for certificates issued before 12th January 2016) or SHA256-WithRSAEncryption	
Issuer Distinguished Name	CN= ESCB-PKI ONLINE CA, O=EUROPEAN SYSTEM OF CENTRAL BANKS, C=EU	
Validity	<i>3 years</i>	
Subject		
C	[Registration Organisation Country]	
O	EUROPEAN SYSTEM OF CENTRAL BANKS	
OU	Organisation within which user is member	
PS	User identifier (UID)	
CN	[AUT:A] Name Middle name Surnames	
Subject Public Key Info		
Algorithm	RSA Encryption	
Minimum Length	2048 bits	
Standard Extensions		
Subject Key Identifier	<i>SHA-1 hash over subject public key</i>	
Authority Key Identifier		
KeyIdentifier	<i>SHA-1 hash over CA Issuer public key</i>	
AuthorityCertIssuer	<i>Not used</i>	
AuthorityCertSerialNumber	<i>Not used</i>	
KeyUsage		Yes
Digital Signature ⁹	1	
Non Repudiation	0	
Key Encipherment	1	
Data Encipherment	0	
Key Agreement	1	
Key Certificate Signature	0	
CRL Signature	0	
extKeyUsage	clientAuth (1.3.6.1.5.5.7.3.2) smartCardLogon (1.3.6.1.4.1.311.20.2.2)	
Certificate Policies		
Policy Identifier	<i>[OID ESCBPKI].2.3.1</i>	
URL CPS	<i>[CPS-URL]</i>	
Subject Alternative Names		
rfc822	<i>Subject's Email</i>	
RegisteredID ([OID ESCBPKI].1.1)	<i>Subject's Name</i>	

⁹ This usage is allowed in the scenarios where a digital signature is generated to authenticate the certificate subscriber

RegisteredID ([OID ESCBPKI].1.2)	<i>Subject's Middle Name (if any)</i>	
RegisteredID ([OID ESCBPKI].1.3)	<i>Subject's Surname</i>	
RegisteredID ([OID ESCBPKI].1.10)	<i>Subject's First surname</i>	
RegisteredID ([OID ESCBPKI].1.4)	<i>Subject's Secondary surname (if any)</i>	
RegisteredID ([OID ESCBPKI].1.7)	<i>ESCB user identifier (UID)</i>	
Basic Constraints		Yes
CA	FALSE	
Path Length Constraint	<i>Not used</i>	
CRL Distribution Points		
Private Extensions		
Authority Information Access		
calssuers	<i>[HTTP URI Root CA]</i>	
calssuers	<i>[HTTP URI Sub CA]</i>	
Ocsp	<i>[HTTP URI OCSP ALIAS]</i> <i>[HTTP URI OCSP]</i> <i>[IAM URI OCSP]</i>	
[ESCB] Extensions		
escbUseCertType	AUTHENTICATION	
escbIssuerName	BANCO DE ESPAÑA	
escbIssuerVAT	VATES-Q2802472G	

7.1.2.2 Advanced signature certificate and advanced signature certificate based on a SSCD

Advanced signature certificate and SSCD signature certificate		
Field	Value	Critical
Base Certificate		
Version	3	
Serial Number	<i>Random</i>	
Signature Algorithm	SHA1-WithRSAEncryption (for certificates issued before 12th January 2016) or SHA256-WithRSAEncryption	
Issuer Distinguished Name	CN= ESCB-PKI ONLINE CA, O=EUROPEAN SYSTEM OF CENTRAL BANKS, C=EU	
Validity	<i>3 years</i>	
Subject		
C	<i>[Registration Organisation Country]</i>	
O	EUROPEAN SYSTEM OF CENTRAL BANKS	
OU	<i>Organisation within which user is member</i>	
PS	<i>User identifier (UID)</i>	
CN	[SIG:Q] <i>Name Middle name Surnames</i> OR [SIG:A] <i>Name Middle name Surnames</i> ¹⁰	
Subject Public Key Info		
Algorithm	RSA Encryption	
Minimum Length	2048 bits	
Standard Extensions		
Subject Key Identifier	<i>SHA-1 hash over subject public key</i>	
Authority Key Identifier		
KeyIdentifier	<i>SHA-1 hash over CA Issuer public key</i>	
AuthorityCertIssuer	<i>Not used</i>	
AuthorityCertSerialNumber	<i>Not used</i>	
KeyUsage		Yes
Digital Signature	0	
Non Repudiation	1	
Key Encipherment	0	
Data Encipherment	0	
Key Agreement	0	
Key Certificate Signature	0	
CRL Signature	0	
extKeyUsage	emailProtection (1.3.6.1.5.5.7.3.4)	
Certificate Policies		
Policy Identifier	<i>[OID ESCBPKI].2.3.4</i> OR <i>[OID ESCBPKI].2.3.5</i> ¹¹	

¹⁰ [SIG:Q] in case of advanced signature certificates based on a SSCD

[SIG:A] in case of advanced signature certificates

¹¹ [OID ESCBPKI].2.3.4 in case of advanced signature certificates based on a SSCD.

[OID ESCBPKI].2.3.5 in case of advanced signature certificates.

URL CPS	[CPS-URL]	
Subject Alternative Names		
rfc822	<i>Subject's Email</i>	
RegisteredID ([OID ESCBPKI].1.1)	<i>Subject's Name</i>	
RegisteredID ([OID ESCBPKI].1.2)	<i>Subject's Middle Name (if any)</i>	
RegisteredID ([OID ESCBPKI].1.3)	<i>Subject's Surname</i>	
RegisteredID ([OID ESCBPKI].1.10)	<i>Subject's First surname</i>	
RegisteredID ([OID ESCBPKI].1.4)	<i>Subject's Secondary surname (if any)</i>	
RegisteredID ([OID ESCBPKI].1.7)	<i>ESCB user identifier (UID)</i>	
Basic Constraints		Yes
CA	FALSE	
Path Length Constraint	<i>Not used</i>	
CRL Distribution Points		
Private Extensions		
Authority Information Access		
calssuers	[HTTP URI Root CA]	
calssuers	[HTTP URI Sub CA]	
Ocsp	[HTTP URI OCSP ALIAS] [HTTP URI OCSP] [IAM URI OCSP]	
qcStatements	id-etsi-qcs-QcCompliance (0.4.0.1862.1.1) Id-etsi-qcs-QcSSCD ¹² (0.4.0.1862.1.4)	
[ESCB] Extensions		
escbUseCertType	SIGNATURE	
escbIssuerName	BANCO DE ESPAÑA	
escbIssuerVAT	VATES-Q2802472G	

¹² Only in the case of advanced signature certificates based on a SSCD.

8.1.1.1 Advanced encryption certificate

Advanced encryption certificate		
Field	Value	Critical
Base Certificate		
Version	3	
Serial Number	Random	
Signature Algorithm	SHA1-WithRSAEncryption (for certificates issued before 12th January 2016) or SHA256-WithRSAEncryption	
Issuer Distinguished Name	CN= ESCB-PKI ONLINE CA, O=EUROPEAN SYSTEM OF CENTRAL BANKS, C=EU	
Validity	3 years	
Subject		
C	[Registration Organisation Country]	
O	EUROPEAN SYSTEM OF CENTRAL BANKS	
OU	Organisation within which user is member	
PS	User identifier (UID)	
CN	[ENC:A] Name Middle name Surnames	
Subject Public Key Info		
Algorithm	RSA Encryption	
Minimum Length	2048 bits	
Standard Extensions		
Subject Key Identifier	SHA-1 hash over subject public key	
Authority Key Identifier		
KeyIdentifier	SHA-1 hash over CA Issuer public key	
AuthorityCertIssuer	Not used	
AuthorityCertSerialNumber	Not used	
KeyUsage		Yes
Digital Signature	0	
Non Repudiation	0	
Key Encipherment	1	
Data Encipherment	1	
Key Agreement	0	
Key Certificate Signature	0	
CRL Signature	0	
extKeyUsage	emailProtection (1.3.6.1.5.5.7.3.4)	
Certificate Policies		
Policy Identifier	[OID ESCBPKI].2.3.2	
URL CPS	[CPS-URL]	
Subject Alternative Names		
rfc822	Subject's Email	
RegisteredID ([OID ESCBPKI].1.1)	Subject's Name	
RegisteredID ([OID ESCBPKI].1.2)	Subject's Middle Name (if any)	
RegisteredID ([OID ESCBPKI].1.3)	Subject's Surname	
RegisteredID ([OID ESCBPKI].1.10)	Subject's First surname	
RegisteredID	Subject's Secondary surname (if any)	

([OID ESCBPKI].1.4) RegisteredID ([OID ESCBPKI].1.7)	<i>ESCB user identifier (UID)</i>	
Basic Constraints CA Path Length Constraint	FALSE <i>Not used</i>	Yes
CRL Distribution Points		
Private Extensions		
Authority Information Access calssuers calssuers ocsp	<i>[HTTP URI Root CA]</i> <i>[HTTP URI Sub CA]</i> <i>[HTTP URI OCSP ALIAS]</i> <i>[HTTP URI OCSP]</i> <i>[IAM URI OCSP]</i>	
[ESCB] Extensions		
escbUseCertType	ENCRYPTION	
escbIssuerName	BANCO DE ESPAÑA	
escbIssuerVAT	VATES-Q2802472G	

8.1.1.2 Standard authentication certificate

Standard authentication certificate		
Field	Value	Critical
Base Certificate		
Version	3	
Serial Number	<i>Random</i>	
Signature Algorithm	SHA1-WithRSAEncryption (for certificates issued before 12th January 2016) or SHA256-WithRSAEncryption	
Issuer Distinguished Name	CN= ESCB-PKI ONLINE CA, O=EUROPEAN SYSTEM OF CENTRAL BANKS, C=EU	
Validity	<i>3 years</i>	
Subject		
C	<i>[Registration Organisation Country]</i>	
O	EUROPEAN SYSTEM OF CENTRAL BANKS	
OU	<i>Organisation within which user is member</i>	
PS	<i>User identifier (UID)</i>	
CN	<i>[AUT:S] Name Middle name Surnames</i>	
Subject Public Key Info		
Algorithm	RSA Encryption	
Minimum Length	2048 bits	
Standard Extensions		
Subject Key Identifier	<i>SHA-1 hash over subject public key</i>	
Authority Key Identifier		
KeyIdentifier	<i>SHA-1 hash over CA Issuer public key</i>	
AuthorityCertIssuer	<i>Not used</i>	
AuthorityCertSerialNumber	<i>Not used</i>	
KeyUsage		Yes
Digital Signature ¹³	1	
Non Repudiation	0	
Key Encipherment ¹⁴	1	
Data Encipherment ¹⁰	1	
Key Agreement	1	
Key Certificate Signature	0	
CRL Signature	0	
extKeyUsage	clientAuth (1.3.6.1.5.5.7.3.2) emailProtection (1.3.6.1.5.5.7.3.4)	
Certificate Policies		
Policy Identifier	<i>[OID ESCBPKI].2.3.6</i>	
URL CPS	<i>[CPS-URL]</i>	
Subject Alternative Names		
rfc822	<i>Subject's Email</i>	
RegisteredID (<i>[OID ESCBPKI].1.1</i>)	<i>Subject's Name</i>	

¹³ This usage is allowed in the scenarios where a digital signature is generated to authenticate the certificate subscriber

¹⁴ keyEncipherment and dataEncipherment are allowed for emailProtection only. The private key is never stored in the Key Archive.

RegisteredID ([OID ESCBPKI].1.2)	<i>Subject's Middle Name (if any)</i>	
RegisteredID ([OID ESCBPKI].1.3)	<i>Subject's Surname</i>	
RegisteredID ([OID ESCBPKI].1.10)	<i>Subject's First surname</i>	
RegisteredID ([OID ESCBPKI].1.4)	<i>Subject's Secondary surname (if any)</i>	
RegisteredID ([OID ESCBPKI].1.7)	<i>ESCB user identifier (UID)</i>	
Basic Constraints		Yes
CA	FALSE	
Path Length Constraint	<i>Not used</i>	
CRL Distribution Points		
Private Extensions		
Authority Information Access		
calssuers	<i>[HTTP URI Root CA]</i>	
calssuers	<i>[HTTP URI Sub CA]</i>	
ocsp	<i>[HTTP URI OCSP ALIAS]</i> <i>[HTTP URI OCSP]</i> <i>[IAM URI OCSP]</i>	
[ESCB] Extensions		
escbUseCertType	AUTHENTICATION	
escbIssuerName	BANCO DE ESPAÑA	
escbIssuerVAT	VATES-Q2802472G	

8.1.2 Algorithm Object Identifiers (OID)

Cryptographic algorithm object identifiers (OID):

SHA-1 with RSA Encryption (1.2.840.113549.1.1.5) – no longer used after 12th January 2016

SHA-256 with RSA Encryption (1.2.840.113549.1.1.11)

8.1.3 Name formats

Certificates issued by ESCB-PKI contain the X.500 distinguished name of the certificate issuer and that of the subject in the issuer name and subject name fields, respectively.

8.1.4 Name constraints

See section 3.1.1.

8.1.5 Certificate Policy Object Identifiers (OID)

The OIDs for this CP are the following¹⁵:

[OID ESCBPKI].2.3.0.X.Y: Certificate policies for the non-ESCB/non-SSM users' certificates (this document)

[OID ESCBPKI].2.3.1.X.Y: Certificate Policy of Advanced Authentication certificate for non-ESCB/non-SSM users

[OID ESCBPKI].2.3.2.X.Y: Certificate Policy of Advanced Encryption certificate for non-ESCB/non-SSM users

[OID ESCBPKI].2.3.4.X.Y: Certificate Policy of Advanced Signature certificate based on a SSCD for non-ESCB/non-SSM users

[OID ESCBPKI].2.3.5.X.Y: Certificate Policy of Advanced Signature certificate for non-ESCB/non-SSM users

[OID ESCBPKI].2.3.6.X.Y: Certificate Policy of Standard Authentication certificate for non-ESCB/non-SSM users

Where:

- [OID ESCBPKI]: represents the OID 0.4.0.127.0.10.1
- X.Y indicate the version.

8.1.6 Use of the "PolicyConstraints" extension

As specified in the ESCB-PKI CPS.

8.1.7 Syntax and semantics of the "PolicyQualifier"

The Certificate Policies extension contains the following Policy Qualifiers:

- URL CPS: contains the URL to the CPS and to the CP that govern the certificate.

The content for certificates regulated under this policy can be seen in point 7.1.2 *Certificate extensions*.

8.1.8 Processing semantics for the critical "CertificatePolicy" extension

As specified in the ESCB-PKI CPS.

8.2 CRL Profile

As specified in the ESCB-PKI CPS.

8.3 OCSP Profile

As specified in the ESCB-PKI CPS.

¹⁵ The OID [OID ESCBPKI].2.3.3 y not used

9 Compliance Audit and Other Assessment

As specified in the ESCB-PKI CPS.

10 Other Business and Legal Matters

10.1 Fees

10.1.1 Certificate issuance or renewal fees

ESCB-PKI will not charge any direct fee to the certificate subscribers for the issuance or renewal of non-ESCB/non-SSM users' certificates.

10.1.2 Certificate access fees

Access to certificates issued under this Policy is free of charge and, therefore, no fee is applicable to them.

10.1.3 Revocation or status information fees

Access to information on the status or revocation of the certificates is open and free of charge and, therefore, no fees are applicable.

10.1.4 Fees for other services, such as policy information

No fee shall be applied for information services on this policy, nor on any additional service that is known at the time of drawing up this document.

10.1.5 Refund policy

Not applicable.

10.2 Financial Responsibility

As specified in the ESCB-PKI CPS.

10.3 Confidentiality of Business Information

10.3.1 Scope of confidential information

As specified in the ESCB-PKI CPS.

10.3.2 Non-confidential information

As specified in the ESCB-PKI CPS. Moreover, a copy of the non-ESCB/non-SSM users' certificates is published in the directory of the ESCB Identity and Access Management (IAM) service.

10.3.3 Duty to maintain professional secrecy

As specified in the ESCB-PKI CPS.

10.4 Privacy of Personal Information

As specified in the ESCB-PKI CPS.

10.4.1 Personal data protection policy

As specified in the ESCB-PKI CPS.

10.4.2 Information considered private

As specified in the ESCB-PKI CPS.

10.4.3 Information not classified as private

As specified in the ESCB-PKI CPS.

10.4.4 Responsibility to protect personal data

As specified in the ESCB-PKI CPS.

10.4.5 Notification of and consent to the use of personal data

The mechanisms to notify certificate applicants and, when appropriate, obtain their consent for the processing of their personal data is the terms and conditions application form.

10.4.6 Disclosure within legal proceedings

As specified in the ESCB-PKI CPS.

10.4.7 Other circumstances in which data may be made public

As specified in the ESCB-PKI CPS.

10.5 Intellectual Property Rights

As specified in the ESCB-PKI CPS.

10.6 Representations and Warranties

As specified in the ESCB-PKI CPS.

10.7 Disclaimers of Warranties

As specified in the ESCB-PKI CPS.

10.8 Limitations of Liability

As specified in the ESCB-PKI CPS.

10.9 Indemnities

As specified in the ESCB-PKI CPS.

10.10 Term and Termination**10.10.1 Term**

This CP shall enter into force from the moment it is approved by the PAA and published in the ESCB-PKI repository.

This CP shall remain valid until such time as it is expressly terminated due to the issue of a new version, or upon re-key of the Corporate CA keys, at which time it is mandatory to issue a new version.

10.10.2 CP substitution and termination

This CP shall always be substituted by a new version, regardless of the importance of the changes carried out therein, meaning that it will always be applicable in its entirety.

When the CP is terminated, it will be withdrawn from the ESCB-PKI public repository; nevertheless it will be kept for 15 years.

10.10.3 Consequences of termination

The obligations and constraints established under this CP, referring to audits, confidential information, ESCB-PKI obligations and liabilities that came into being whilst it was in force shall continue to prevail following its substitution or termination with a new version in all terms which are not contrary to said new version.

10.11 Individual notices and communications with participants

As specified in the ESCB-PKI CPS.

10.12 Amendments

As specified in the ESCB-PKI CPS.

10.13 Dispute Resolution Procedures

As specified in the ESCB-PKI CPS.

10.14 Governing Law

As specified in the ESCB-PKI CPS.

10.15 Compliance with Applicable Law

As specified in the ESCB-PKI CPS.

10.16 Miscellaneous Provisions***10.16.1 Entire agreement clause***

As specified in the ESCB-PKI CPS.

10.16.2 Independence

Should any of the provisions of this CP be declared invalid, null or legally unenforceable, it shall be deemed as not included, unless said provisions were essential in such a way that excluding them from the CP would render the latter without legal effect.

10.16.3 Resolution through the courts

As specified in the ESCB-PKI CPS.

10.17 Other Provisions

As specified in the ESCB-PKI CPS.